

# MS125

## HYDRAULIC MOTORS

	C	A	B	C	D	E	N
	mm[in]	mm[in]	mm[in]	mm[in]	mm[in]	mm[in]	mm[in]
	1 1 1 0 1 2 3 4 P	Ø 175.7 [6.92 dia.]	Ø 225 [8.86 dia.]	Ø 265 [10.43 dia.]	253.45 [9.98]	Ø 334 [13.15 dia.]	Ø 291 [11.46 dia.]
	1 2 1 0 1 2 3 4 P	Ø 220.7 [8.69 dia.]	Ø 275 [10.83 dia.]	Ø 314 [12.36 dia.]	253.25 [9.97]	Ø 291 [11.46 dia.]	Ø 220.7 [8.69 dia.]
	1 7 1 0 1 2 3 4 P	Ø 220.7 [8.69 dia.]	Ø 275 [10.83 dia.]	Ø 314 [12.36 dia.]	253.25 [9.97]	Ø 334 [13.15 dia.]	Ø 291 [11.46 dia.]
	1 3 1 0 1 2 3 4 P	Ø 175.7 [6.92 dia.]	Ø 225 [8.86 dia.]	Ø 276 [10.87 dia.]	208.75 [8.22]	Ø 334 [13.15 dia.]	Ø 291 [11.46 dia.]
	1 4 1 0 1 2 3 4 P	Ø 220.7 [8.69 dia.]	Ø 254 [10.00 dia.]	Ø 285 [11.22 dia.]	163.2 [6.43]	Ø 334 [13.15 dia.]	Ø 291 [11.46 dia.]
	1 1 1 0 1 2 3 4 P	Ø 175.7 [6.92 dia.]	Ø 225 [8.86 dia.]	Ø 265 [10.43 dia.]	253.45 [9.98]	Ø 334 [13.15 dia.]	Ø 291 [11.46 dia.]
	1 2 1 0 1 2 3 4 P	Ø 220.7 [8.69 dia.]	Ø 275 [10.83 dia.]	Ø 314 [12.36 dia.]	253.25 [9.97]	Ø 291 [11.46 dia.]	Ø 220.7 [8.69 dia.]
	1 7 1 0 1 2 3 4 P	Ø 220.7 [8.69 dia.]	Ø 275 [10.83 dia.]	Ø 314 [12.36 dia.]	253.25 [9.97]	Ø 334 [13.15 dia.]	Ø 291 [11.46 dia.]
	1 3 1 0 1 2 3 4 P	Ø 175.7 [6.92 dia.]	Ø 225 [8.86 dia.]	Ø 276 [10.87 dia.]	208.75 [8.22]	Ø 334 [13.15 dia.]	Ø 291 [11.46 dia.]
	1 4 1 0 1 2 3 4 P	Ø 220.7 [8.69 dia.]	Ø 254 [10.00 dia.]	Ø 285 [11.22 dia.]	163.2 [6.43]	Ø 334 [13.15 dia.]	Ø 291 [11.46 dia.]
	1 2 1 0 1 2 3 4 P	Ø 220.7 [8.69 dia.]	Ø 275 [10.83 dia.]	Ø 314 [12.36 dia.]	253.25 [9.97]	Ø 291 [11.46 dia.]	Ø 220.7 [8.69 dia.]
	1 7 1 0 1 2 3 4 P	Ø 220.7 [8.69 dia.]	Ø 275 [10.83 dia.]	Ø 314 [12.36 dia.]	253.25 [9.97]	Ø 334 [13.15 dia.]	Ø 291 [11.46 dia.]
	1 3 1 0 1 2 3 4 P	Ø 175.7 [6.92 dia.]	Ø 225 [8.86 dia.]	Ø 276 [10.87 dia.]	208.75 [8.22]	Ø 334 [13.15 dia.]	Ø 291 [11.46 dia.]
	1 4 1 0 1 2 3 4 P	Ø 220.7 [8.69 dia.]	Ø 254 [10.00 dia.]	Ø 285 [11.22 dia.]	163.2 [6.43]	Ø 334 [13.15 dia.]	Ø 291 [11.46 dia.]

T E C H N I C A L C A T A L O G





# CHARACTERISTICS

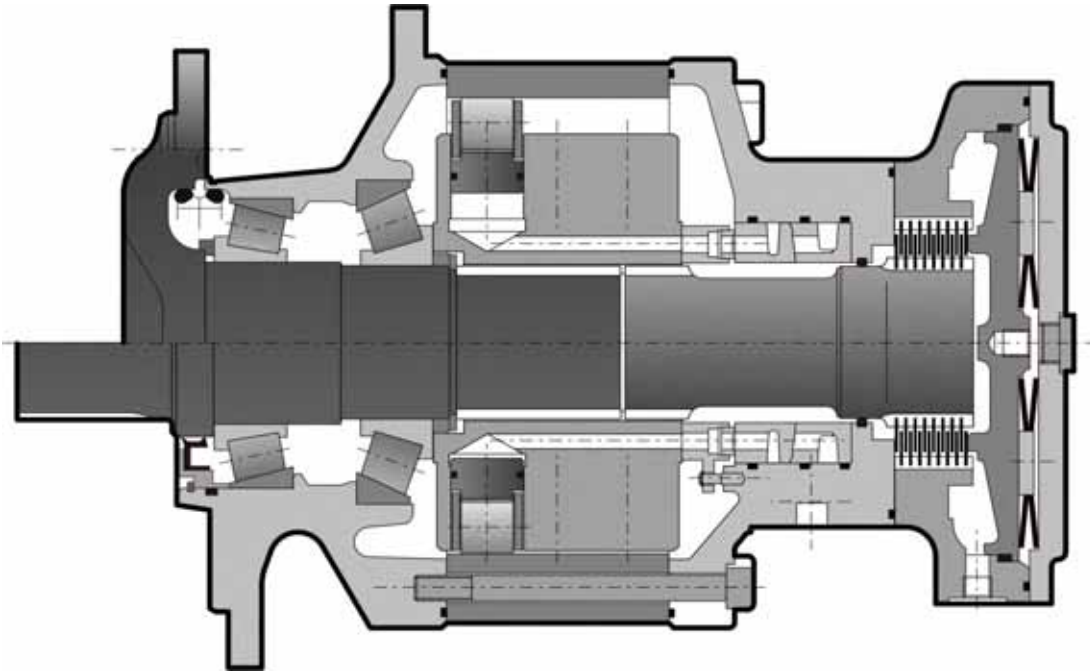

Motor inertia 2 kg.m<sup>2</sup>



	C	1	2	Theoretical torque		Max.power		Max. speed		Max. pressure P					
				at 100 bar		at 1000 PSI									
				cm <sup>3</sup> /tr [cu.in/rev.]	cm <sup>3</sup> /tr [cu.in/rev.]	Nm	[lb.ft]	kW [HP]	kW [HP]	tr/min [RPM]	tr/min [RPM]	bar [PSI]			
Cams with equal lobes	8	10 000 [609.9]	5 000 [305.0]	15 900	[8 086]			50	50	450	420				
	0	12 500 [762.4]	6 250 [381.2]	19 875	[10 107]	240 [322]	160 [215]	40	40	380	335				
	2	15 000 [914.9]	7 500 [457.4]	23 850	[12 128]			30	30	320	280				
Cams with unequal lobes	A	12 500 [762.4]	7 500 [457.4]	19 875	[10 107]	240 [322]	160 [215]	30	30	380	335				
			5 000 [305.0]												

1 First displacement

2 Second displacement

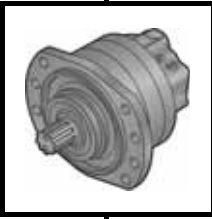

# CONTENT

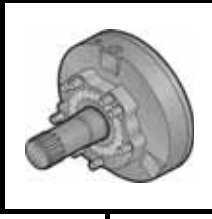
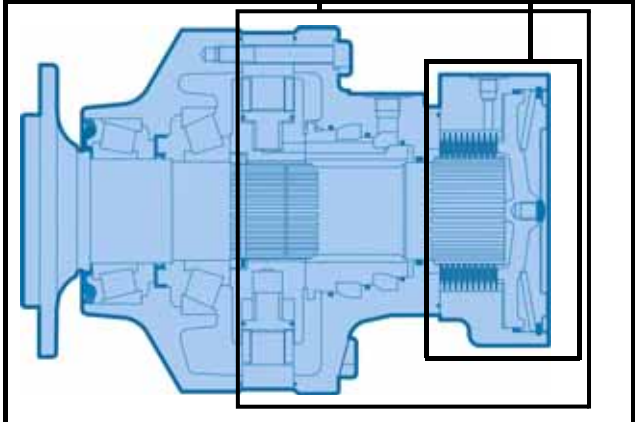
	<b>MODULARITY</b>	<b>4</b>	Modularity and Model code
	<b>MODEL CODE</b>	<b>6</b>	
	<b>WHEEL MOTOR</b>	<b>9</b>	Wheel motor
	Dimensions for standard (4310) 1-displacement motor	9	
	Dimensions for standard (4310) 2-displacement motor	9	
	Support types	10	
	Studs	10	
	Load curves	11	
	<b>SHAFT MOTOR</b>	<b>13</b>	Shaft motor
	Dimensions for standard (3A50) 1-displacement motor	13	
	Dimensions for standard (3A50) 2-displacement motor	13	
	Support types	14	
	Splined coupling	14	
	Cylindrical bushed coupling	15	
	Load curves	15	
	<b>VALVING SYSTEMS AND HYDROBASES</b>	<b>17</b>	Valving systems and hydrobases
	Dimensions for 1-displacement valving	17	
	Dimensions for 2-displacement symmetrical valving	18	
	Chassis mountings	19	
	Hydraulic connections	20	
	Efficiency	21	
	<b>BRAKES</b>	<b>23</b>	Brake
	Rear brake	23	
	<b>OPTIONS</b>	<b>25</b>	Options



# MODUL

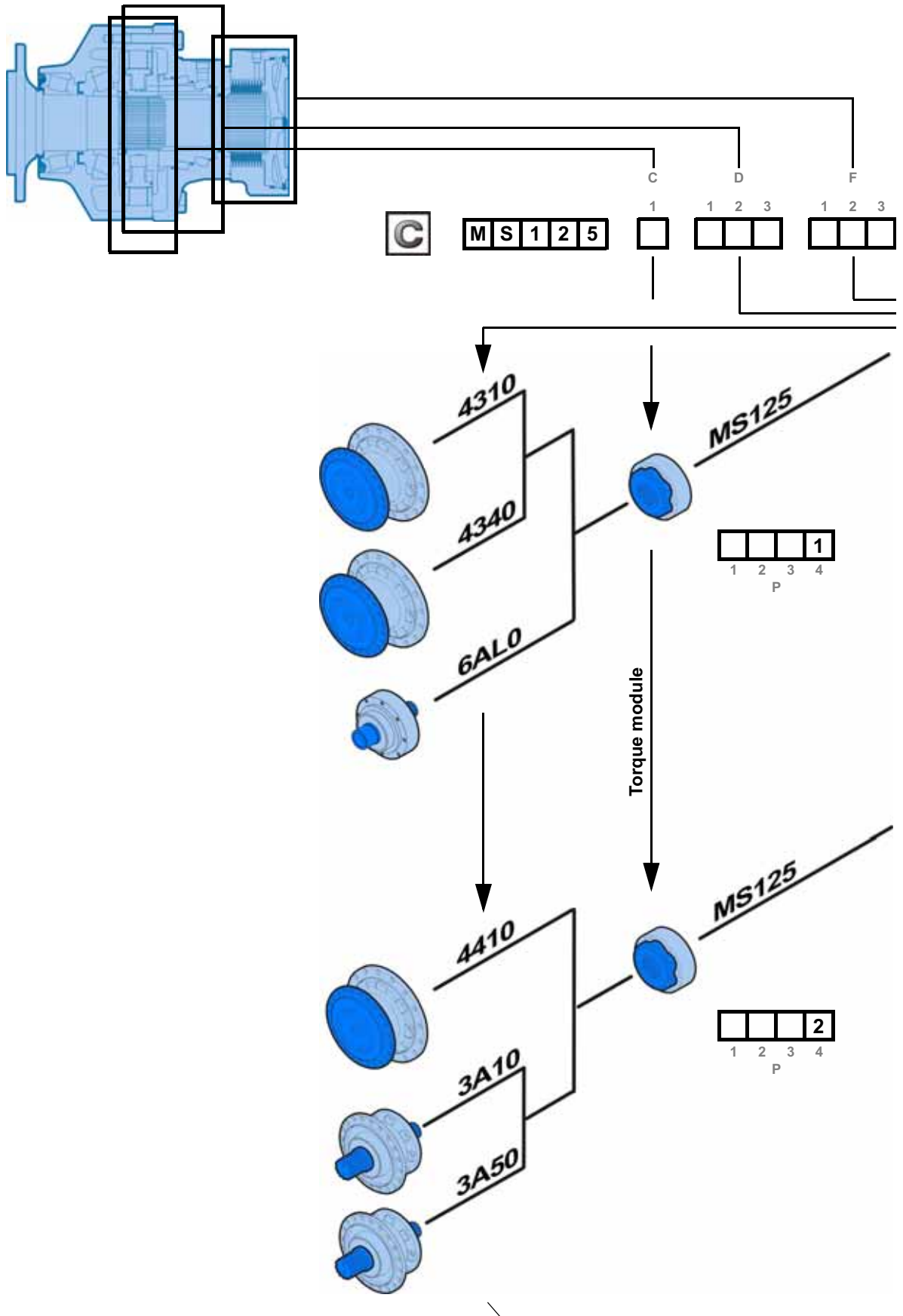



# ARITY

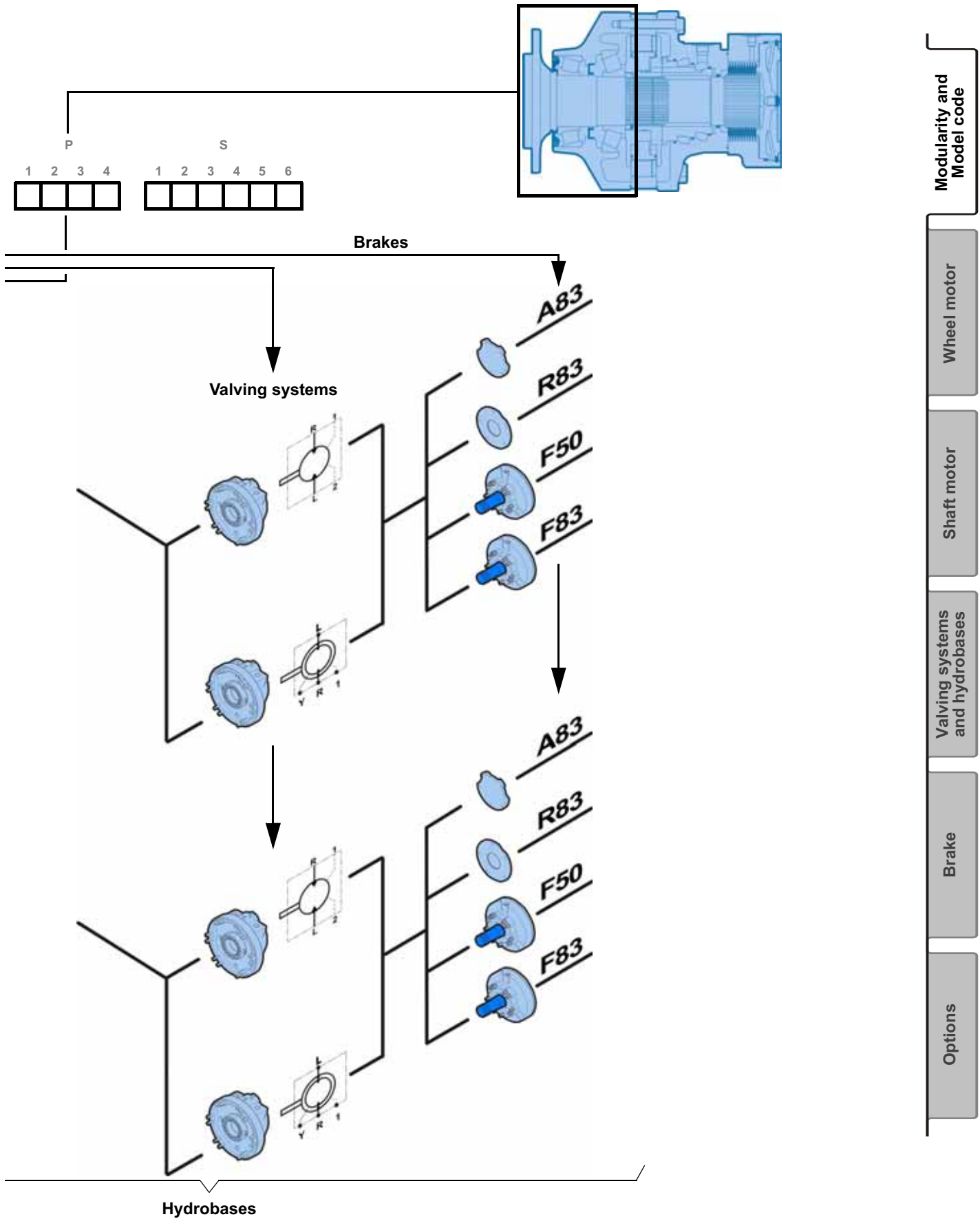



# MODEL

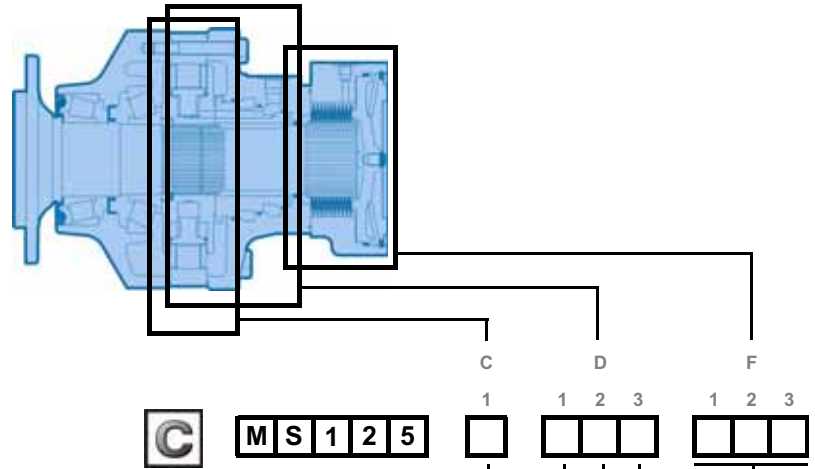

	①		②	
	cm <sup>3</sup> /tr [cu.in/rev.]		cm <sup>3</sup> /tr [cu.in/rev.]	
Cams with equal lobes	8	10 000 [609,9]	5 000 [305,0]	
	0	12 500 [762,4]	6 250 [381,2]	
	2	15 000 [914,9]	7 500 [457,4]	
Cams with unequal lobes	A	12 500 [762,4]	7 500 [457,4]	5 000 [305,0]

- ① First displacement
- ② Dual displacement

1-displacement valving	1
	A Ratio 2
Symmetrical	B Ratio <2
	C Ratio >2

Without mounting	1
Lug fixing	2

Without cover	0
ISO DP6162 flanges	1
ISO 9974-1 connections	

Without brake (simple plate)	A	8	3
Brakes	F	5	0
	F	8	3
Without brake (reinforced plate)	R	8	3



# CODE

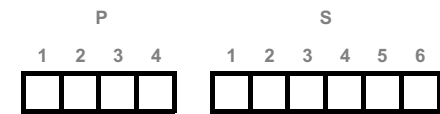
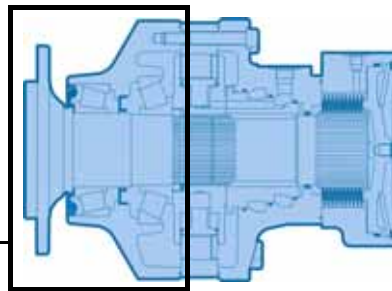

- 0 Without bearing support
- 3 Flange close to shaft
- 4 Flange close to cam
- 6 Motor torque

- Without shaft 0
- 24 x Ø26 onØ425 3
- 24 studs M24 x 2 x 115 mm 3
- 24 x Ø26 onØ425 4
- 24 studs M24 x 2 x 95 mm 4
- Bearing support for shaft A

- Without shaft 0
- Without studs 1
- With studs + nuts 2
- With studs 3
- M threaded holes 4

**Male shafts**

- NF E 22 141 splines 1
- DIN 5480 splines 5
- Female shafts for shrink disks L

- Cylinder-block splines DIN 5480 1
- Cylinder-block splines NF E 22-141 2

- Without Options or Adaptations 0
- T4 Speed sensor installed 2
- Industrial bearing support 6
- Diamond™ 7
- Predisposition for speed sensor 8
- Hollow shaft A
- Drain on the bearing support B
- Special paint or without paint D
- Reinforced sealing E
- Special wheel rim mounting G
- Surface heat treatment of the shaft J
- TR Speed sensor installed S

Modularity and Model code

Wheel motor

Shaft motor

Valving systems and hydrobases

Brake

Options



**Methodology :**

This document is intended for manufacturers of machines that incorporate Poclain Hydraulics products. It describes the technical characteristics of Poclain Hydraulics products and specifies installation conditions that will ensure optimum operation. This document includes important comments concerning safety. They are indicated in the following way:



**Safety comment.**

This document also includes essential operating instructions for the product and general information. These are indicated in the following way:



**Essential instructions.**



**General information .**



**Information on the model number. Information on the model code.**



**Weight of component without oil.**



**Volume of oil.**



**Units.**



**Tightening torque.**



**Screws.**



**Information intended for Poclain-Hydraulics personnel.**

The views in this document are created using metric standards.  
The dimensional data is given in mm and in inches (inches are between brackets and italic)





# WHEEL MOTOR

## Dimensions for standard (4310) 1-displacement motor

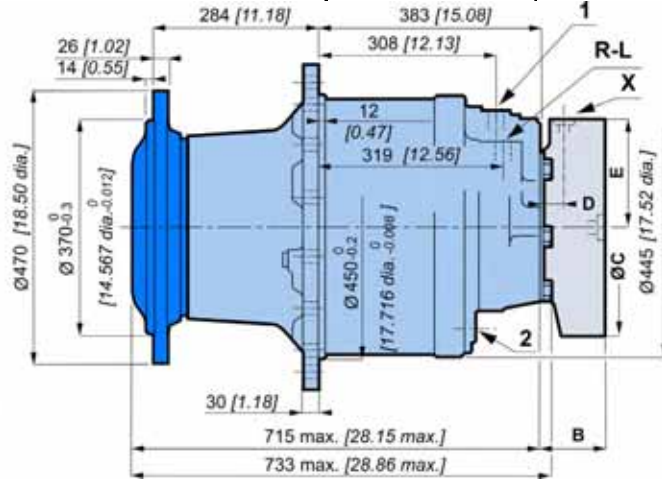
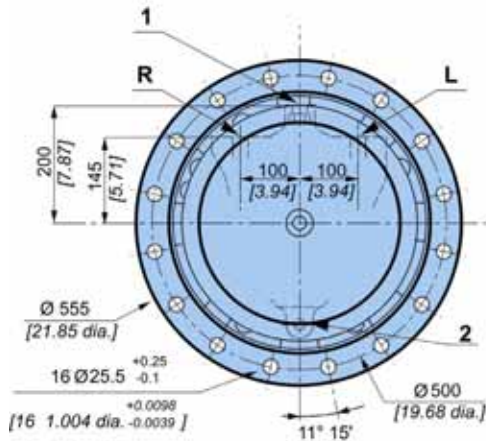

	460 kg [1 012 lb]	563 kg [1 239 lb]
	11,00 L [660 cu.in]	9,00 L [540 cu.in]

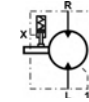
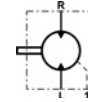

Modularity and Model code

Wheel motor

Shaft motor

## Dimensions for standard (4310) 2-displacement motor

For a small displacement, there is no preferred orientation for this motor.

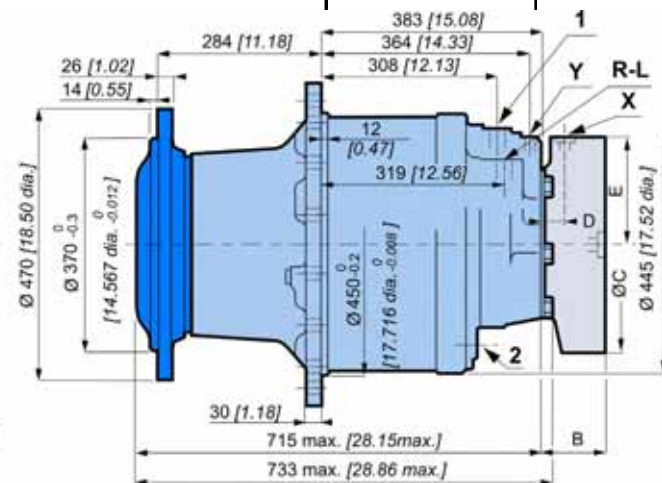
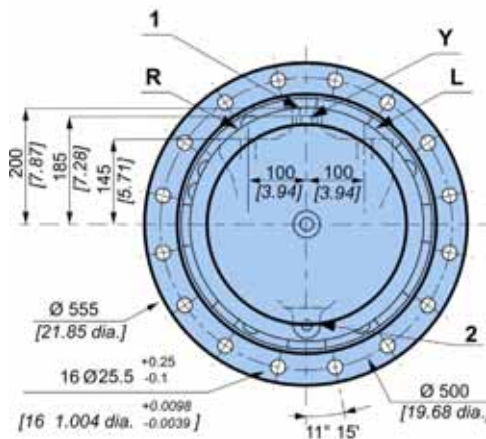

	460 kg [1 012 lb]	563 kg [1 239 lb]
	11,00 L [660 cu.in]	9,00 L [540 cu.in]

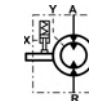
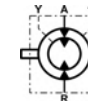

Valving systems and hydrobases

Brake



Also see 'Valving systems and hydrobases' section (thumbnail opposite).

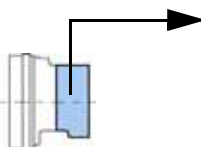

<b>C</b>	<b>F 5 0</b>	<b>F 8 3</b>
B	152 [5.98]	152 [5.98]
C	Ø375 [14.76 dia.]	Ø375 [14.76 dia.]
D	63.5 [2.50]	63.5 [2.50]
E	183.5 [7.22]	183.5 [7.22]



Also see 'Brakes' section (thumbnail opposite).

Options



**Support types**

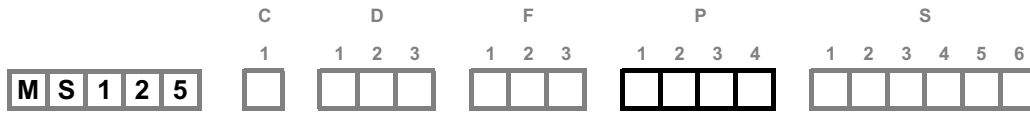

	A mm [in]	B mm [in]	C mm [in]	D mm [in]	E mm [in]	N mm [in]	Wheel rim mountings	L mm [in]
	Ø 370 [14,57 dia.]	Ø 425 [16,73 dia.]	Ø 470 [18,50 dia.]	284 [11,18]	Ø 445 [17,52 dia.]	Ø 26 [1,02 dia.]	24 x M24x2	26 [1,02]
	Ø 370 [14,57 dia.]	Ø 425 [16,73 dia.]	Ø 470 [18,50 dia.]	239 [9,41]	Ø 445 [17,52 dia.]	Ø 26 [1,02 dia.]	24 x M24x2	25 [0,98]

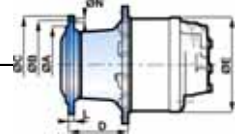

**Studs**

		P mm [in]	C min. mm [in]	C max. mm [in]	D mm [in]	Class	(1) * N.m [lb.ft]	(2) * N.m [lb.ft]
Studs	M24 x 2	95 [3.74] 115 [4.53]	5 [0.20]	39 [1.54] 59 [2.32]	30 [1.18]	12.9	910 [671.2]	1 150 [848.2]
Screws	M24 x 2	-	-	-	-	12.9	910 [671.2]	1 150 [848.2]

(\* ) The tightening torques are given for the indicated loads.

(1) **Wheel rim** : Suggested tightening torque for wheel rim mountings (Re steel disc > 240 N/mm<sup>2</sup> [>34 800 PSI]).

(2) **Standard** : Suggested tightening torque in other cases (Re steel flange 360 > N/mm<sup>2</sup> [>52 215 PSI])



See generic installation motors N°801478197L.



Load curves

Permissible radial loads

Test conditions :

**Static** : 0 tr/min [0 RPM] 0 bar [0 PSI]

**Dynamic** : 0 tr/min [0 RPM], code 0 displacement, without axial load at max. torque

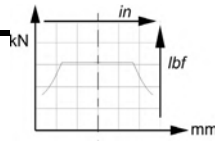

Service life of bearings

Test conditions :

L : Millions B10 revolutions at 150 bars (average pressure), with 25 cSt fluid, code 0 displacement, without axial load.

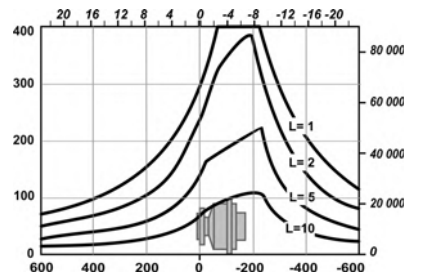
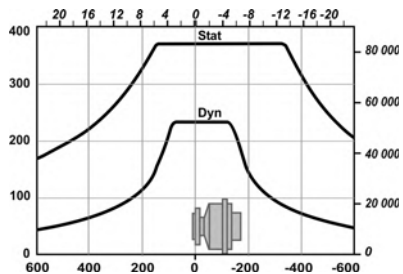
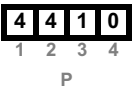
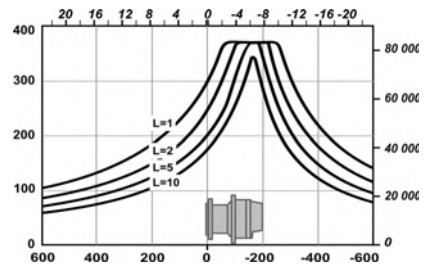
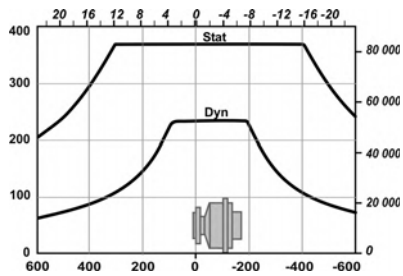
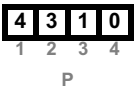

The service life of the components is influenced by the pressure. You must check that the combination of forces applied (Axial load / Radial load) is compatible with the permissible loads for the components, and that the resulting service lives of these components complies with the application's specifications. For an accurate calculation, consult your Poclair Hydraulics application engineer.



Modularity and Model code

Wheel motor

Shaft motor

Valving systems and hydrobases

Brake

Options





# SHAFT MOTOR

## Dimensions for standard (3A50) 1-displacement motor

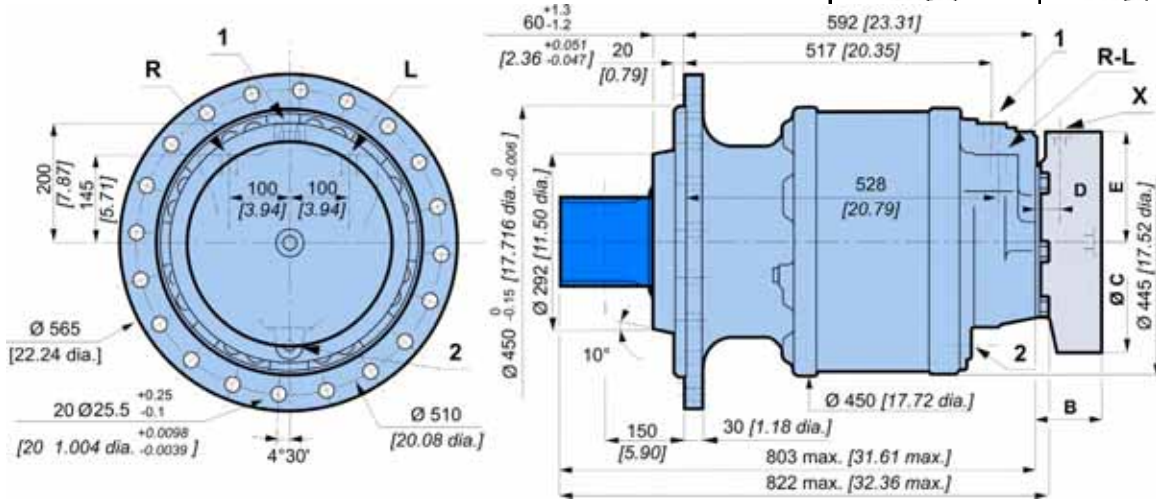

	470 kg [1 034 lb]	573 kg [1 261 lb]
	11,00 L [660 cu.in]	9,00 L [540 cu.in]

Modularity and Model code

Wheel motor

Shaft motor

## Dimensions for standard (3A50) 2-displacement motor

For a small displacement, there is no preferred orientation for this motor.

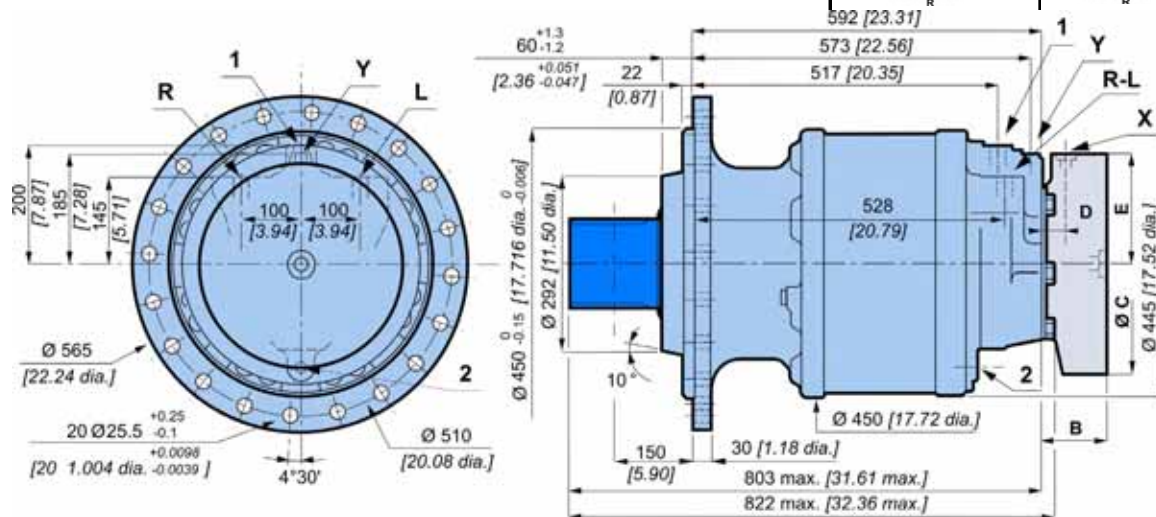

	470 kg [1 034 lb]	573 kg [1 261 lb]
	11,00 L [660 cu.in]	9,00 L [540 cu.in]

Valving systems and hydrobases

Brake

Options

Also see 'Valving systems and hydrobases' section (thumbnail opposite).

	<b>C</b>	<b>F 5 0</b>	<b>F 8 3</b>
	B	152 [5.98]	152 [5.98]
	C	Ø375 [14.76 dia.]	Ø375 [14.76 dia.]
	D	63.5 [2.50]	63.5 [2.50]
	E	183.5 [7.22]	183.5 [7.22]

Also see 'Brakes' section (thumbnail opposite).



Support types

				C	D			F			P				S					
				1	1	2	3	1	2	3	1	2	3	4	1	2	3	4	5	6
<b>M S 1 2 5</b>				□	□ □ □			□ □ □			□ □ □ □				□ □ □ □ □ □					
<b>C</b>				<b>A</b>	<b>B</b>	<b>C</b>	<b>D</b>	<b>E</b>	<b>F</b>	<b>G</b>										
				mm [in]	mm [in]	mm [in]	mm [in]	mm [in]	mm [in]	mm [in]										
<b>NF E22-141 splines</b>																				
<b>3 A 1 0</b>				Nominal Ø 150 [5,91]	40 [1,57]	R 4 [R 0,16]	60 [2,36]	2 x M16	31 [1,22]	150 [5,91]										
1 2 3 4 P				Module 3.75																
				Z 38																
<b>DIN 5480 splines</b>																				
<b>3 A 5 0</b>				Nominal Ø 150 [5,91]	40 [1,57]	R 4 [R 0,16]	60 [2,36]	2 x M16	32 [1,26]	150 [5,91]										
1 2 3 4 P				Module 5																
				Z 28																
<b>6 A L 0</b>				Ø 155 [6,10 dia.]	Ø 200 [7,87 dia.]	230 [9,06]	495 [19,49]	Ø 352 [13,86 dia.]	Ø 394 [15,51 dia.]	16 x M24										
1 2 3 4 P																				

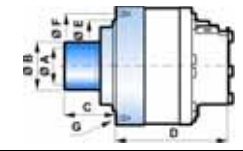
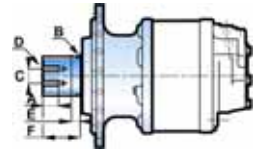

Also see 'Valving systems and hydrobases' section (thumbnail opposite).

Splined coupling

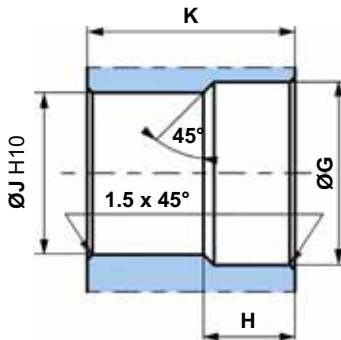

**N** : Nominal Ø.  
**Mo** : Module.  
**Z** : Number of teeth.

**Standard DIN 5480**  
Pressure angle 30°. Centering on flanks. Slide adjustment (7H quality).

**Standard NF E 22-141**  
Pressure angle 20°. Centering on flanks. Slide adjustment (7H quality).

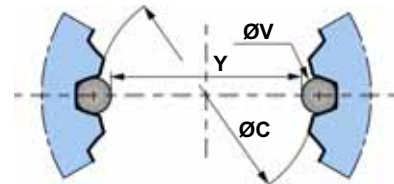

<b>C</b>				Ø G	H	Ø J	K	N	Mo	Z	Offset	Ø C (H10)	Ø V	Y	Tolerance
				mm [in]	mm [in]	mm [in]	mm [in]	mm [in]			mm [in]	mm [in]	mm [in]	µm [µin]	
<b>3 A 1 0</b>				151 [5,94]	32 [1,26]	142,5 [5,61]	149 [5,87]	150 [5,91]	3,75	38	3 [0,12]	142,5 [5,61]	7,5 [0,30]	135,254 [5,32]	+ 104 / 0 [+4.094 / 0]
1 2 3 4 P															
<b>3 A 5 0</b>				152 [5,98]	33 [1,30]	140 [5,51]	149 [5,87]	150 [5,91]	5	28	2,25 [0,0886]	140 [5,51]	9 [0,35]	131,104 [5,16]	+ 87 / 0 [+3.425 / 0]
1 2 3 4 P															

General tolerances : ± 0.25 [±0.0098].

Material : Ex: 42CrMo4.

Hardening treatment to obtain R = 800 to 900 N/mm² [R = 116 030 to 130 533 PSI].



**Cylindrical bushed coupling**

	A	B	C	D
	mm [in]	mm [in]	mm [in]	mm [in]
<b>6 A L 0</b> 1 2 3 4 P	Ø 155 [6,10 dia.]	140 [5,51]	10 [0,394]	0,5 [0,0197]

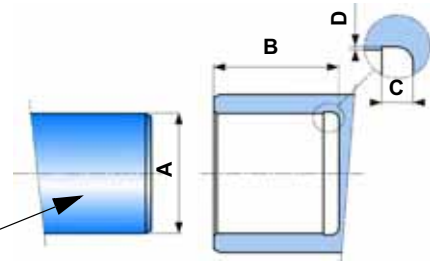

$R_{min.} : 640 \text{ N/mm}^2 [132\ 800 \text{ PSI}]$

**Load curves**

**Permissible radial loads**

Test conditions :

**Static** : 0 tr/min [0 RPM] 0 bar [0 PSI]

**Dynamic** : 0 tr/min [0 RPM], code 0 displacement, without axial load at max. torque

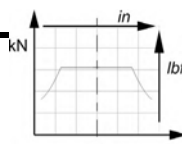

**Service life of bearings**

Test conditions :

**L** : Millions B10 revolutions at 150 bars (average pressure), with 25 cSt fluid, code 0 displacement, without axial load.

<b>3 A 1 0</b>	1	2	3	4
<b>3 A 5 0</b>	1	2	3	4

P

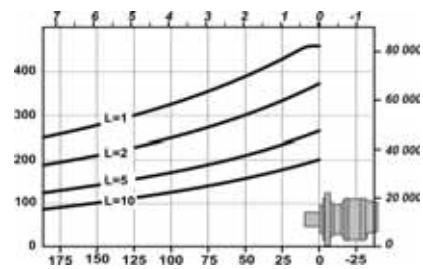
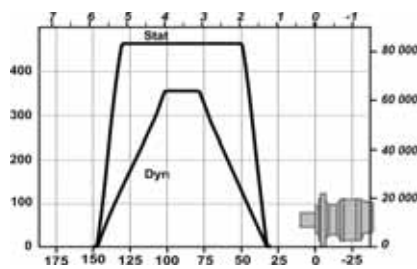

<b>6 A L 0</b>	1	2	3	4
----------------	---	---	---	---

P

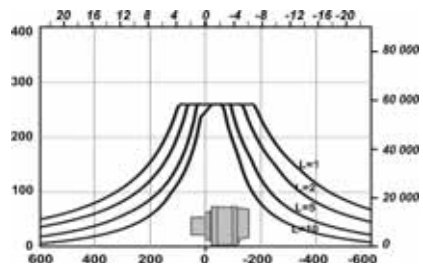
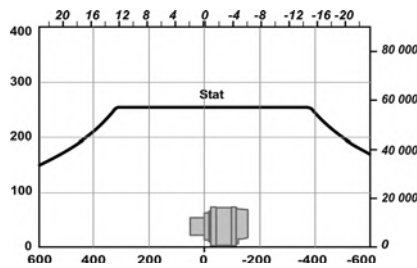

The service life of the components is influenced by the pressure. You must check that the combination of forces applied (Axial load / Radial load) is compatible with the permissible loads for the components, and that the resulting service lives of these components complies with the application's specifications. For an accurate calculation, consult your Poclain Hydraulics application engineer.

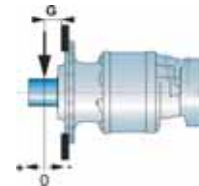

	G
	mm [in]
<b>3 A 1 0</b>	151 [5.94]
<b>3 A 5 0</b>	151 [5.94]
<b>6 A L 0</b>	65.75 [2.589]

Modularity and Model code

Wheel motor

Shaft motor

Valving systems and hydrobases

Brake

Options





# VALVING SYSTEMS AND HYDROBASES



## Dimensions for 1-displacement valving

	301 kg [661 lb]	399 kg [878 lb]
	4,50 L [270 cu.in]	4,00 L [240 cu.in]

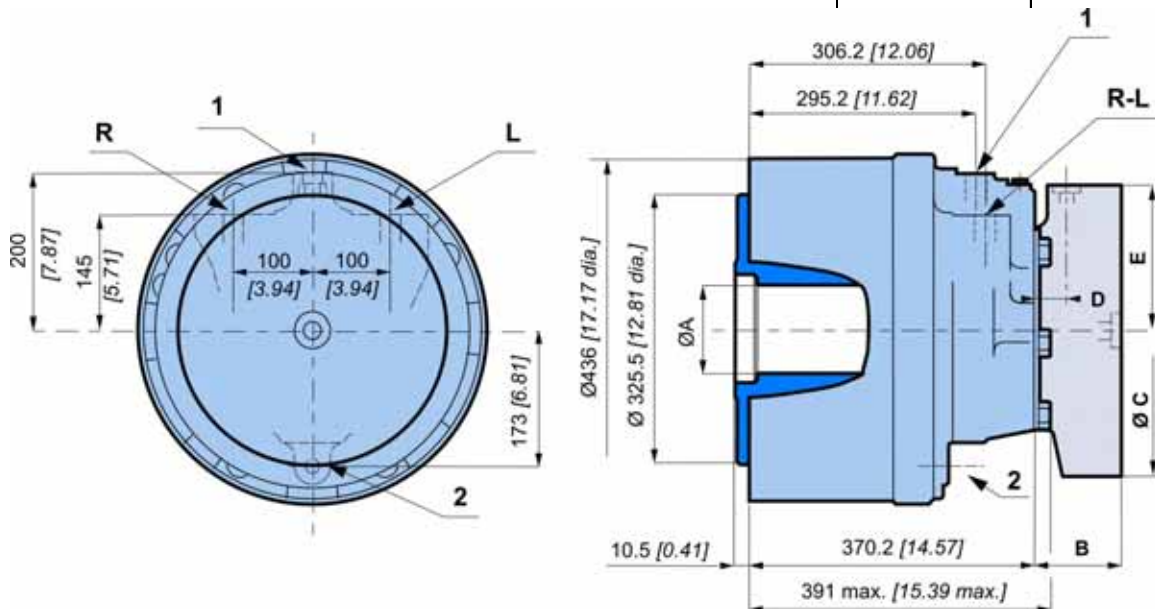

	<b>C</b>	<b>F 5 0</b>	<b>F 8 3</b>
	B	152 [5.98]	152 [5.98]
	C	Ø375 [14.76 dia.]	Ø375 [14.76 dia.]
	D	63.5 [2.50]	63.5 [2.50]
	E	183.5 [7.22]	183.5 [7.22]

Also see 'Brakes' section (thumbnail opposite).

## Cylinder block splines

standard	ØA	Module	Z	Dimension on 2 pins		<b>C</b>
				Y	ØV	
DIN 5480	130 [5,118]	3	42	119,078 [4,688]	5,25 [0,207]	1
NF E22 141	120 [4,724]	3,75	30	105,253 [4,144]	7,5 [0,295]	2

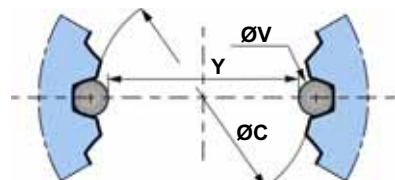

You are advised to have the installation validated by your Poclair Hydraulics application engineer before using the hydraulic unit in an application.



We must provide you with a detailed plan of the interface for any hydraulic unit use, consult your Poclair Hydraulics sales engineer.

Modularity and Model code

Wheel motor

Shaft motor

Valving systems and hydrobases





Brake

Options





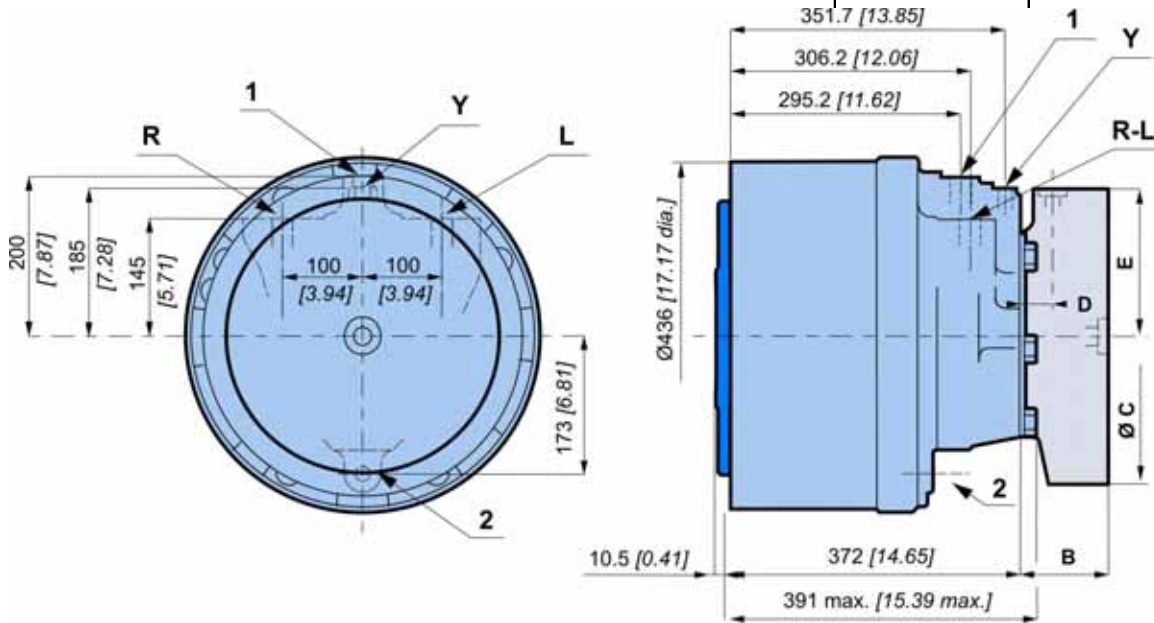

**Dimensions for 2-displacement symmetrical valving**

For a small displacement, there is no preferred orientation for this motor.

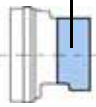
	301 kg [661 lb]	399 kg [878 lb]
	4,50 L [270 cu.in]	4,00 L [240 cu.in]
		



			
	<b>B</b>	152 [5.98]	152 [5.98]
	<b>C</b>	Ø375 [14.76 dia.]	Ø375 [14.76 dia.]
	<b>D</b>	63.5 [2.50]	63.5 [2.50]
	<b>E</b>	183.5 [7.22]	183.5 [7.22]



 Also see 'Brakes' section (thumbnail opposite).

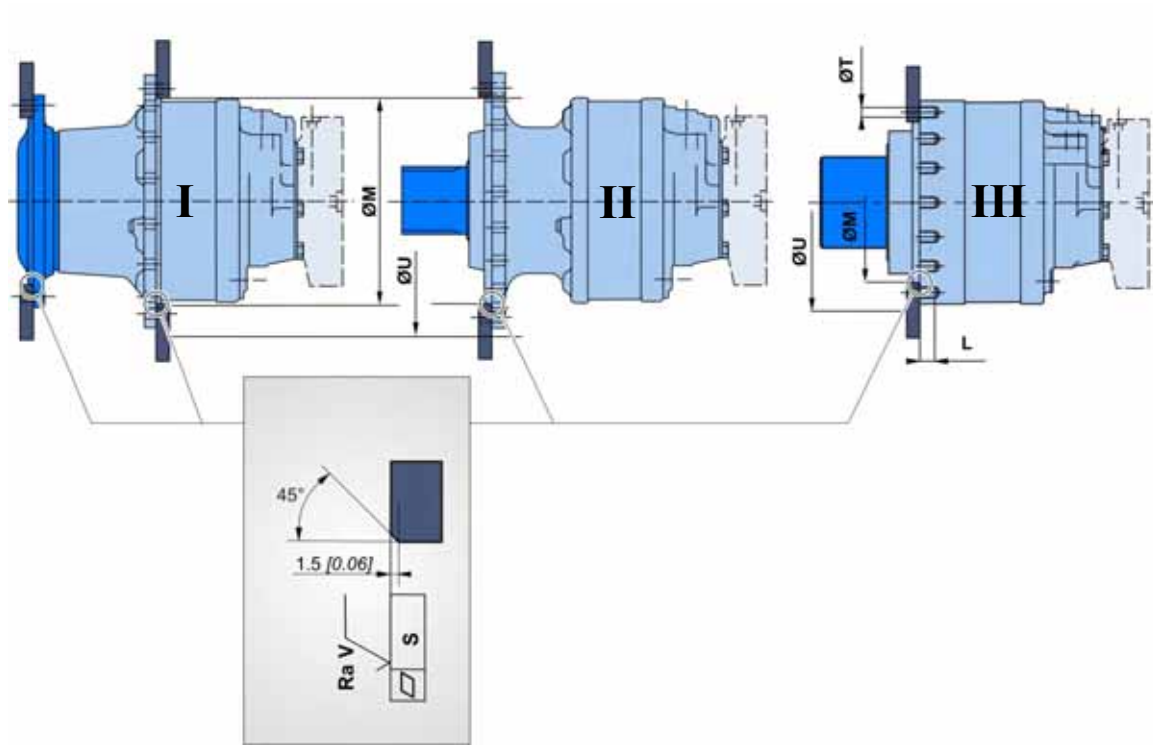

Chassis mountings



Take care over the immediate environment of the connections.

	ØM <sup>(1)</sup> mm [in]	ØU mm [in]	ØT mm [in]	L mm [in]	S mm [in]	Ra V µm [µin]		Class	 * N.m [lb.ft]
<b>I</b>	450 [17,72]	565 [22,24]	-	-	0,2 [0,008]	12,5 [0,49]	16 x M24	<b>12,9</b>	1 200 [885,1]
<b>II</b>							20 x M24		
<b>III</b>	352 [13,86]	446 [17,56]	25,5 [1,004]	35 [1,378]	16 x M24	1200 [885,1]			

(1) +0,3 [+0,012]  
+0,2 [+0,008]

\* : Min. values for torque and load to be transmitted.

Modularity and Model code

Wheel motor

Shaft motor

Valving systems and hydrobases

Brake

Options



## Hydraulic connections

connections

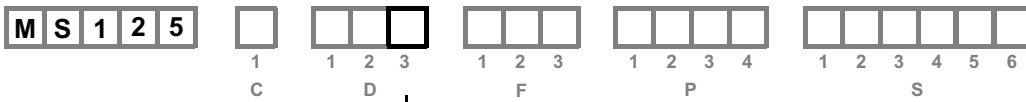
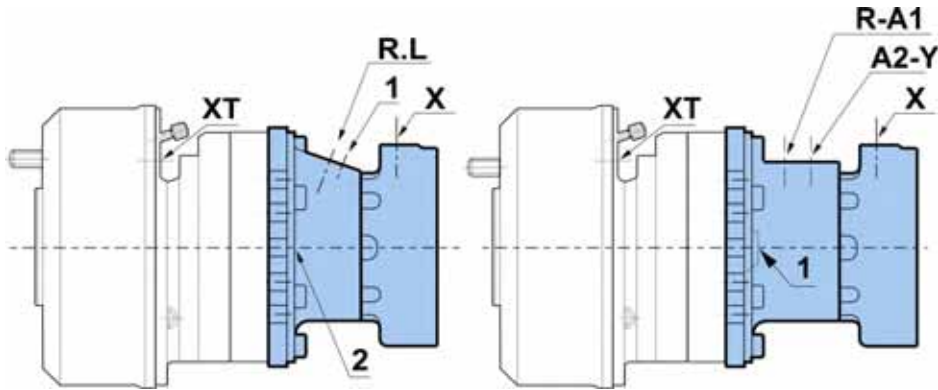

	Old standards	Standards	Power supply	Case drain	2 <sup>nd</sup> displacement control	Control of parking break
	1	ISO 6 162 DIN 3 852	ISO 6 162 ISO 9 974-1	R-L DN32 PN400	1, 2	X M18x1.5
	1	ISO 6 162 DIN 3 852	ISO 6 162 ISO 9 974-1	R-L DN32 PN400	1, 2 Y M18x1.5	X M18x1.5
<b>Max. pressures</b>	<b>MS</b>	<b>bar [PSI]</b>		450 [6 527]	1 [15]	30 [435]



You are strongly advised to use the fluids specified in brochure "Installation guide" N° 801478197L.



To find the connections' tightening torques, see the brochure "Installation guide" N° 801478197L.



## Efficiency

### Overall efficiency

Average values given for guidance for code 0 displacement after 100 hours of operation with HV46 hydraulic fluid at 50°C [122°F].

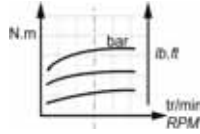
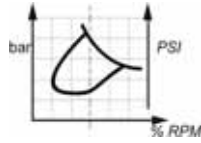

### Actual output torque

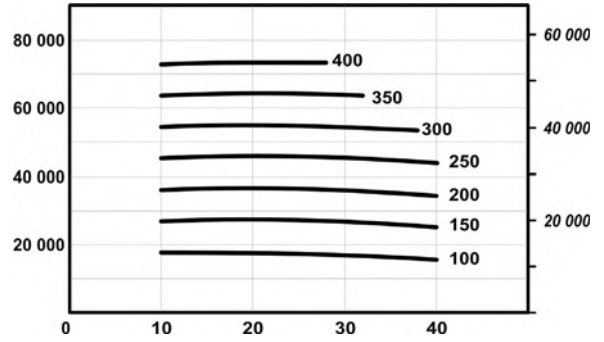
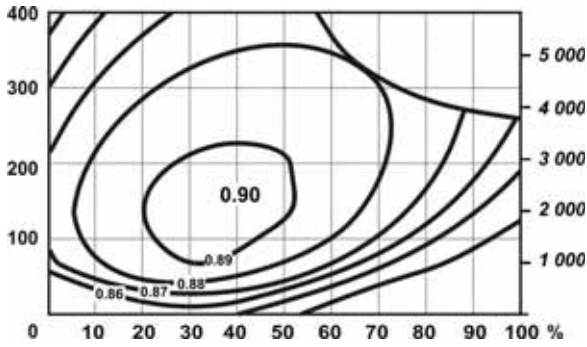

The starting torque is taken to be approximately 85% of the first value for available pressure. For a precise calculation, consult your Poclain Hydraulics application engineer.

Modularity and Model code

Wheel motor

Shaft motor

Valving systems and hydrobases

Brake

Options





# BRAKES

## Rear brake

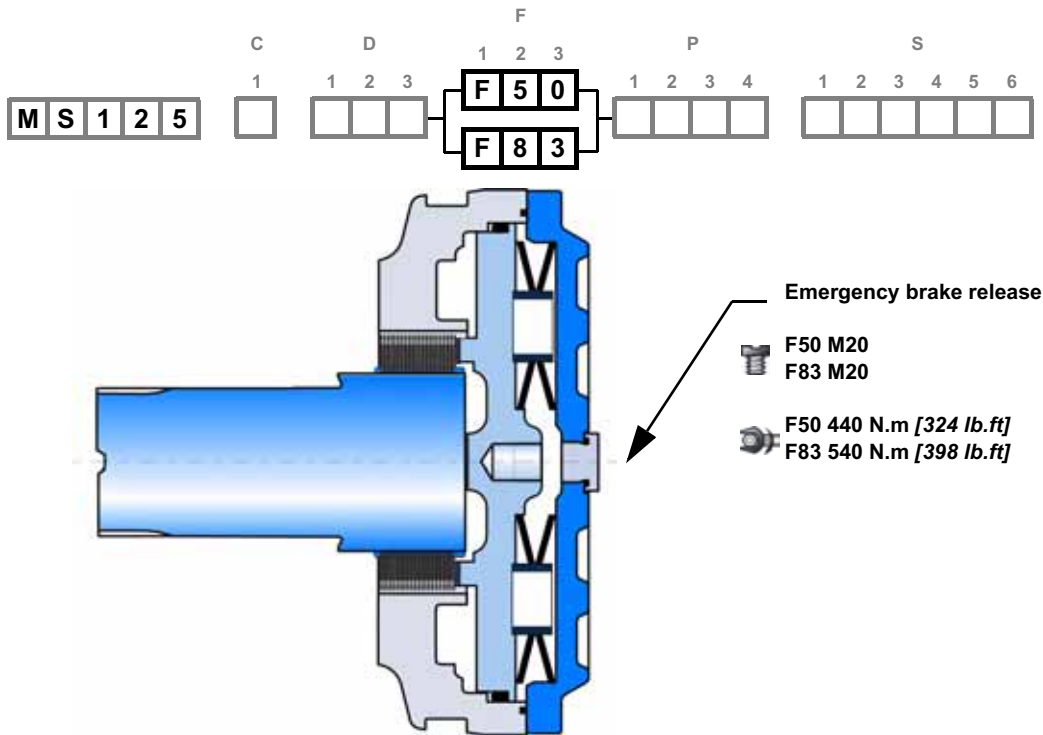

### Brake principle

This is a multidisc brake which is activated by a lack of pressure. The spring exerts a force on the piston, which presses on the fixed and mobile discs, and immobilizes the shaft. The braking torque decreases in linear proportion to the brake release pressure.

<b>C</b>	<b>F 5 0</b>	<b>F 8 3</b>
Parking brake torque at 0 bars on housing (new brake)	30 000 Nm [22 130 lb.ft]	42 000 Nm [30 980 lb.ft]
Dynamic emergency braking torque at 0 bars on housing	19 500 Nm [14 380 lb.ft]	27 300 Nm [20 140 lb.ft]
Residual parking braking at 0 bars on housing *	22 500 Nm [16 600 lb.ft]	31 500 Nm [23 230 lb.ft]
Min. brake release pressure	12 bar [174 PSI]	14 bar [203 PSI]
Max. brake release pressure	30 bar [435 PSI]	30 bar [435 PSI]
Oil capacity	450 cm <sup>3</sup> [27,5 cu.in]	450 cm <sup>3</sup> [27,5 cu.in]
Volume for brake release	135 cm <sup>3</sup> [8,2 cu.in]	135 cm <sup>3</sup> [8,2 cu.in]

\* After emergency brake has been used



**Do not run in multidisc brakes.**



**A functional check of the parking brake must be carried out each time it is used as an auxiliary brake (or emergency brake). For all vehicles capable of speeds over 25 km/hour, please contact your Poclair Hydraulics application engineer.**

Modularity and Model code

Wheel motor

Shaft motor

Valving systems and hydrobases

Brake

Options





# OPTIONS

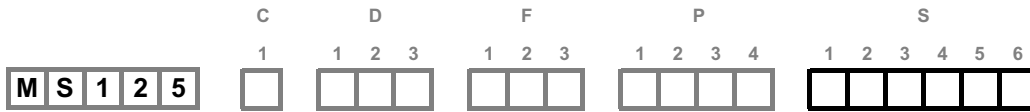

You can accumulate more than one optional part. Consult your Poclair Hydraulics sales engineer.

## 2 - S - 8 - Installed speed sensor or predisposition

### Designation

T4 Speed sensor installed	<b>2</b>
TR Speed sensor installed (direction of rotation)	<b>S</b>
Predisposition for speed sensor	<b>8</b>

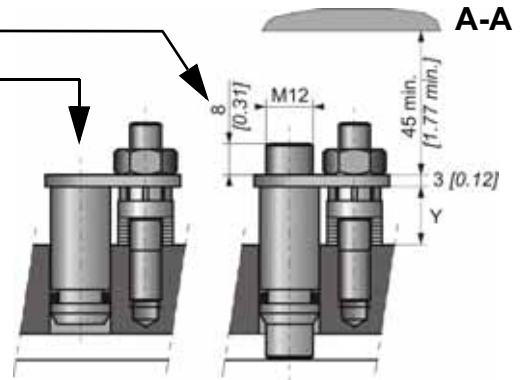
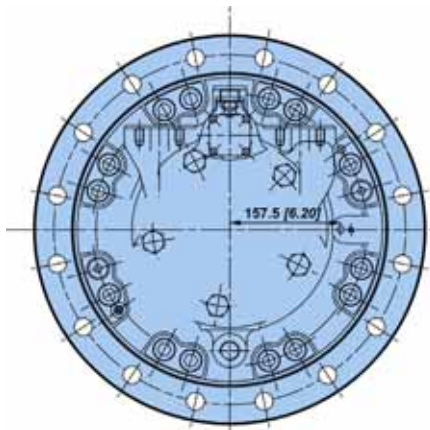

Max. length Y= 14.8

Standard number of pulses per revolution= 60



Look at the "Mobile Electronic" N° A01889D technical catalogue for the sensor specifications and its connection.



To install the sensor, see the "Installation guide" brochure No. 801478197L.

## 6 - Industrial support

Reduction of around 50% from the rated value in the bearings' preload value.



For a precise calculation, consult your Poclair Hydraulics application engineer.

## 7 - Diamond™

Special treatment of the motor core which considerably increases its strength, making the motor much more tolerant to temporary instances of the operating conditions being exceeded.

Modularity and Model code

Wheel motor

Shaft motor

Valving systems and hydrobases

Brake

Options



**A - Hollow shaft**

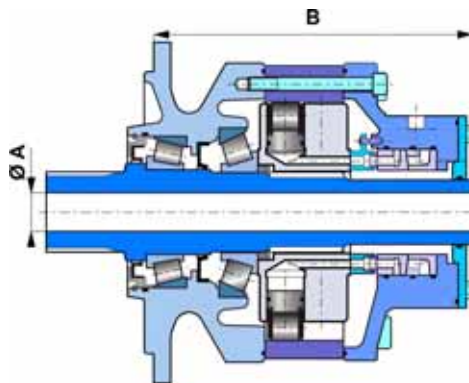

A	B
mm [in]	mm [in]
Ø 75 [2,95 dia.]	686 [27,01]

Radial load x 0.75  
No torque transmittable to the rear

**B - Drain on the bearing support**

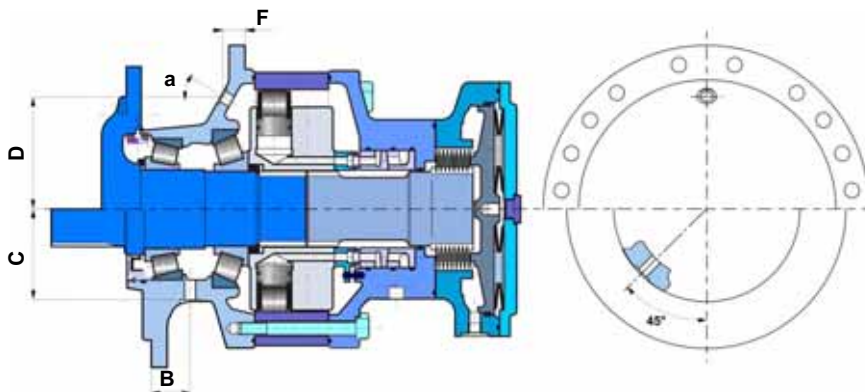

	B	C	D	F	a
	mm [in]	mm [in]	mm [in]	mm [in]	
Shaft motor	-	-	187 [7,36]	40 [1,57]	36°
Wheel motor	70 [2,76]	185 [7,28]	-	-	-

**E - Reinforced sealing**

Requires reinforced seals and, for an unbraked motor, a rear reinforced plate (R83 - 15 [0.594] thick, instead of 6 [0.237]).

	C	D	F	P	S
	1	1 2 3	1 2 3	1 2 3 4	1 2 3 4 5 6
<b>M S 1 2 5</b>	<input type="checkbox"/>	<input type="checkbox"/>	<b>R 8 3</b>	<input type="checkbox"/>	<b>E</b>

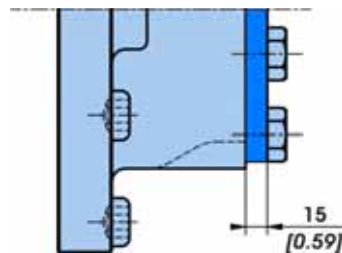



### G - Special wheel rim mounting

Enables certain combinations different from the standard mountings defined on page 10.



Consult your Poclair Hydraulics sales engineer.

### J - Treated shaft

Heat treatment on the indicated bearing radius and splines.

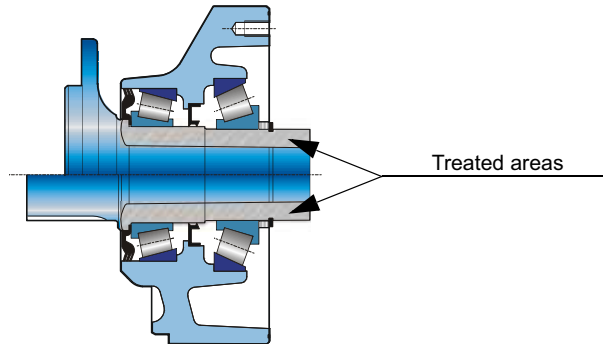

### N - Drain on the bearing

A purge screw enables the motor to be mounted vertically, the shaft oriented upward.

Thirteen subsidiaries and a worldwide network  
of more than 150 distributors and partners ...

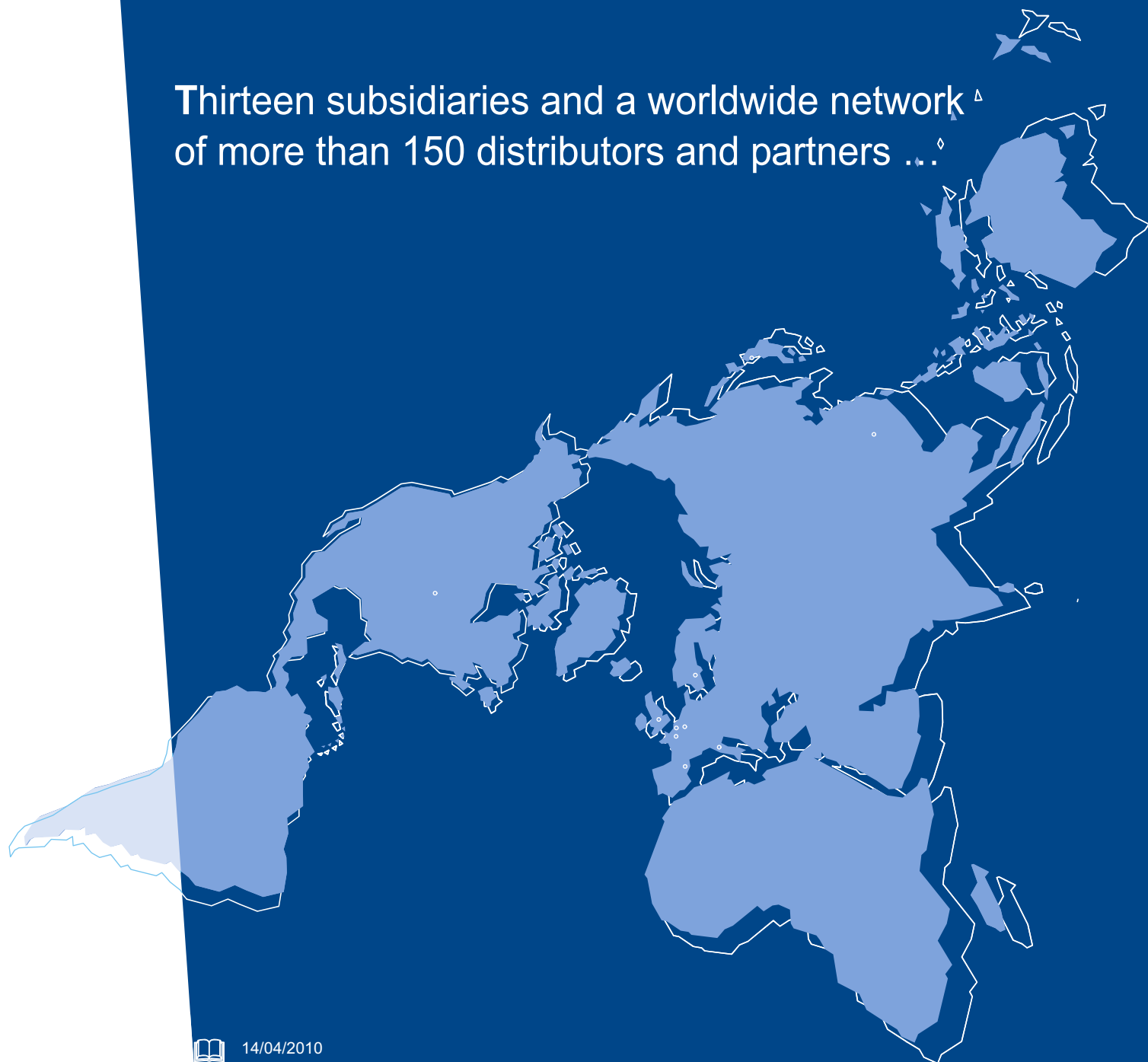

	14/04/2010
	801 478 126J
	801 478 196K
	801 578 109L
	801 578 121Z
	801 578 133M
	Not available
	Not available
	A14248M

*Poclain Hydraulics reserves the right to make any modifications it deems necessary to the products described in this document without prior notification. The information contained in this document must be confirmed by Poclain Hydraulics before any order is submitted.*

*Illustrations are not binding.*

*The Poclain Hydraulics brand is the property of Poclain Hydraulics S.A.*